

Project Details			
Name	91 Louis Drive	Date	03/08/2023
Location	91 Louis Drive, West Sand Lake, NY 12196	ASCE code	7.10
Total modules	15	Wind speed	105 mph
Module	Silfab: SIL-400-NU (38mm)	Snow load	40 psf
Dimensions	Dimensions: 79.76" x 39.61" x 1.5" (2026.0mm x 1006.0mm x 38.0mm)	Wind exposure	B
Total watts	6,000 kW	Piers	10

Substructure & Foundation			
Tilt	25°	South facing grade	0°
Pipe/tubing diameter	2"	Soil class	2 - 5
Foundation type	Ground screws	Screw length	63" (1600mm)
Freeze thaw depth		Hex head set screws / Screw	4

Sub array #1					
Rows	3	Columns	5	# Arrays	1
Area	33' 4" (EW) × 10' 2" (NS)	Rail type	XR1000	Diagonal bracing	no
E/W spacing	7'	Rail cantilever	1' 4"	Pipe cantilever	2' 8"
Piers/array	10	Total south piers	5 (4')	Total north piers	5 (7' 6")
Total cross pipes	2 (33' 4")	Total pipe length	124' 1"		
Shear	500 lbs	Moment	1,250 ft-lbs	Uplift	-612 lbs

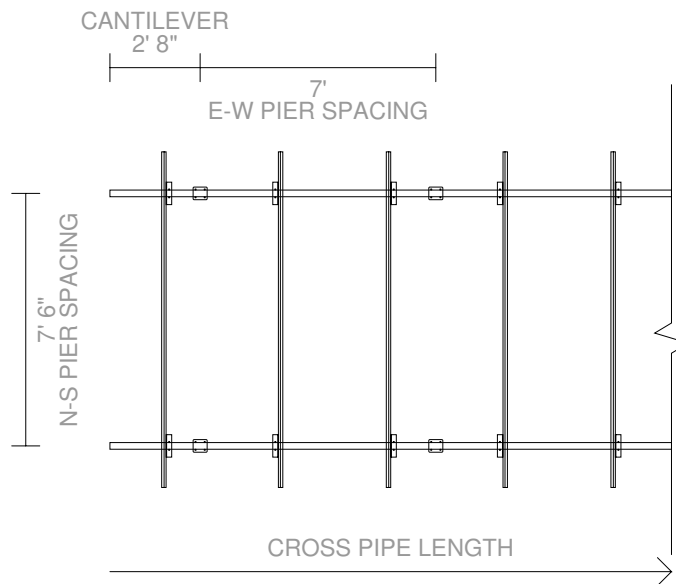

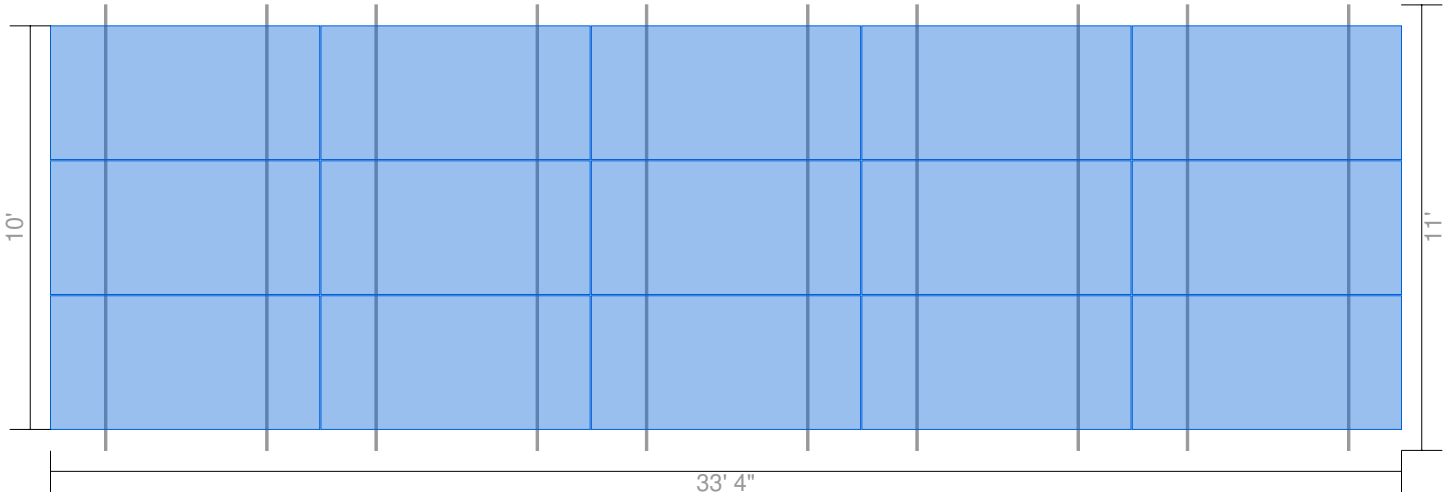
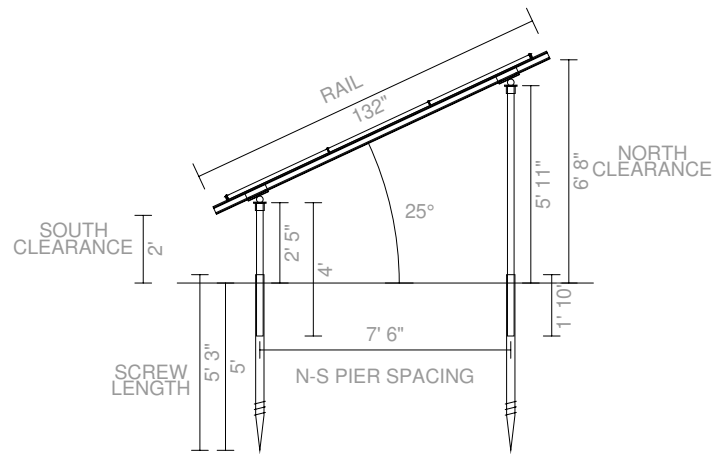

Pipe Fitting Detail

XR1000 Rail

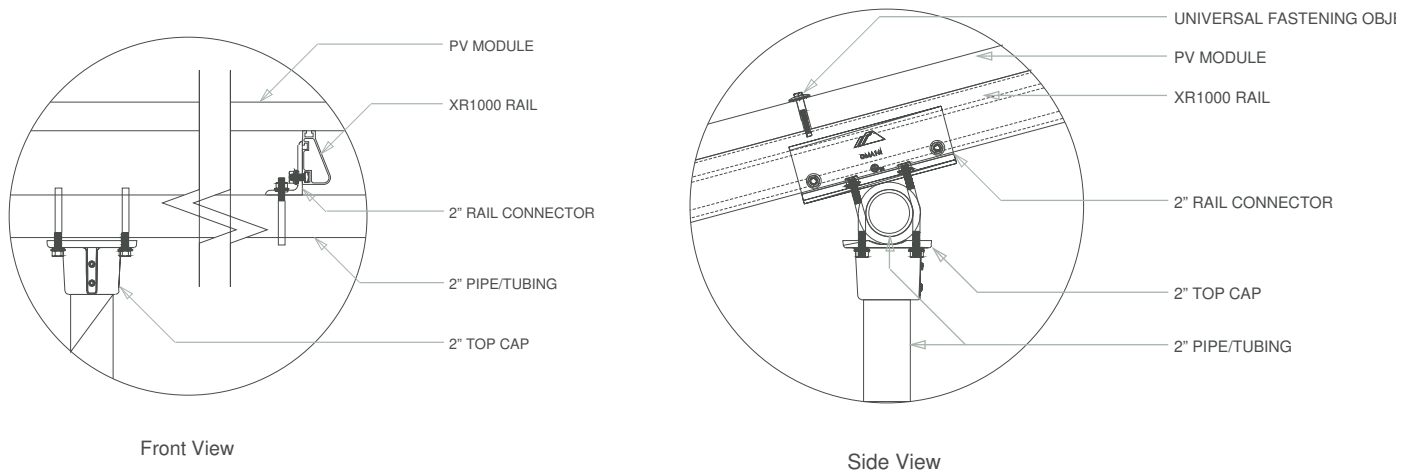

Clamp Detail

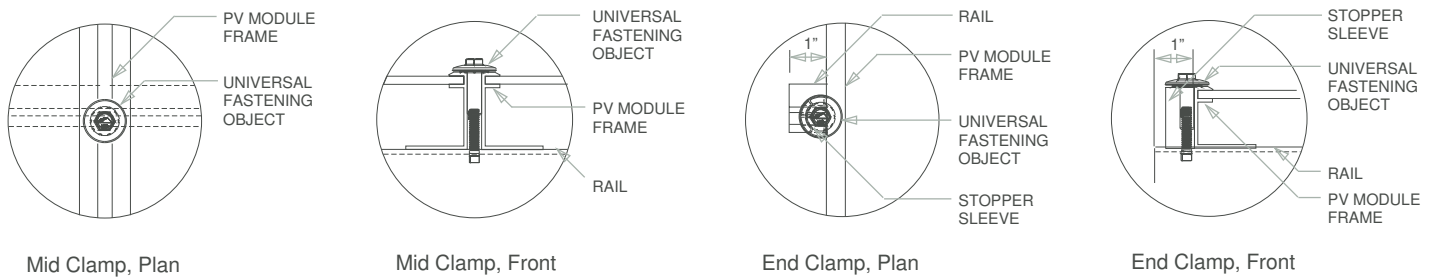

Grounding Diagram

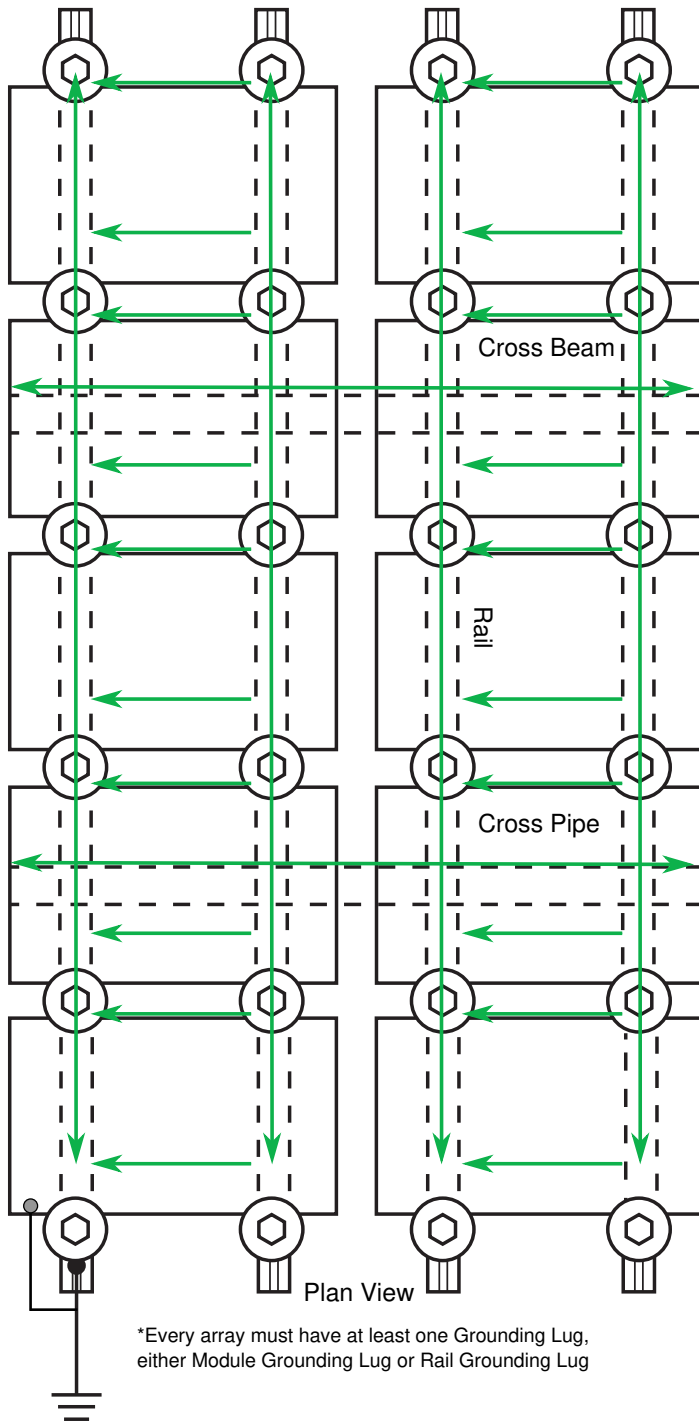

	UFO or CAMO		Rail Grounding Lug*
	Module Grounding Lug*		Fault Current Ground Path
	Min 10 AWG Copper Wire		Bonding Point

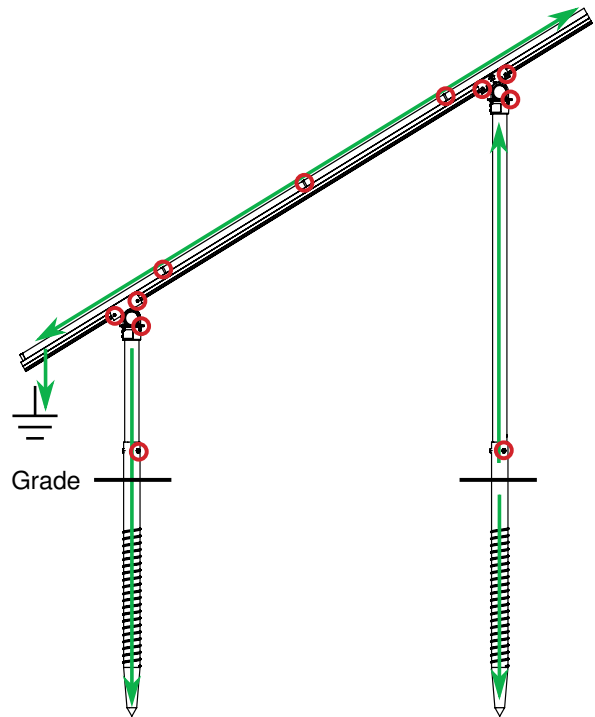

*Grounding Lugs and wire are not required in systems using certain Enphase microinverters or certain Sunpower modules. Equipment grounding is achieved with the Engage cable for Enphase or the AC module cable system for Sunpower via their integrated EGC.

Bill of Materials

Part	Spares	Total Qty
Rails		
XR-1000-132A XR1000, Rail 132" (11 Feet) Clear * [Custom Length] Please check with your distributor for availability.	0	10
Clamps & Grounding		
UFO-CL-01-A1 Universal Module Clamp, Clear	20	60
UFO-STP-38MM-M1 Stopper Sleeve, 38MM, Mill	12	32
XR-LUG-03-A1 Grounding Lug, Low Profile	0	1
Substructure		
70-0200-SGA SGA Top Cap at 2"	0	10
GM-BRC-002 Ground Mount Bonded Rail Connector - 2"	0	20
GM-HSHW-01-M1 Hex Head Set Screw	-40	0
Accessories		
29-4000-077 Wire Clips, Molded PVC Black, Polybag 20	0	2
XR-1000-CAP Kit, End Cap XR1000 (10 sets per bag)	0	1
BHW-MI-01-A1 Microinverter/MLPE Bonding Hardware, T-Bolt	20	35



Starling Madison Lofquist, Inc.
Consulting Structural and Forensic Engineers

3600 E. University Dr. Suite 1400, Phoenix, Arizona 85034
tel: (602) 438-2500 fax: (602) 438-2505 ROC#291316 www.smleng.com

IronRidge
28357 Industrial Boulevard
Hayward, CA 94545

August 1, 2022

Attn: Mr. Corey Geiger, VP New Markets, IronRidge Inc.

Subject: Ground Mounting System with Ground Screws – Structural Analysis – 4 Module (XR1000)

Dear Sir:

We have analyzed the subject ground mounted structure and determined that it is in compliance with the applicable sections of the following Reference Documents:

Codes: ASCE/SEI 7-10 Min. Design Loads for Buildings & Other Structures
ASCE/SEI 7-16 Min. Design Loads for Buildings & Other Structures
International Building Code, 2015 Edition
International Building Code, 2018 Edition
Other: AC428, Acceptance Criteria for Modular Framing Systems Used to Support PV
Modules, dated Effective November 1, 2012 by ICC-ES
CTL Thompson Testing Report for Ground Screw Lateral Testing, dated November 20, 2020
American Ground Screw, Inc. ESR-4226
Aluminum Design Manual, 2015 Edition
IronRidge Exhibit EX-0021

The structure is a simple column (pier) and beam (cross pipe) system. The piers & cross pipes are ASTM A53 Grade B standard weight (schedule 40) steel pipes or Allied Mechanical Tubing. Please refer to Exhibit EX-0021 for approved pipe geometry and material properties. The tops of the piers are connected in the E-W direction by the cross pipes which cantilever over and extend past the end piers. The cross pipes are connected by proprietary IronRidge XR1000 Rails spanning up and down the slope which cantilever over and extend past the top and bottom cross pipes. There are typically two rails per column of modules. The modules are clamped to the rails by the IronRidge Module Mounting Clamps as shown in the attached Exhibit.

Gravity loads are transferred to the piers and ground screws by the rails and cross pipes acting as simple beams. For lateral loads the system is a cantilever structure. The effect of seismic loads (for all design categories A-F) have been determined to be less than the effect due to wind loads in all load conditions and combinations.

The pier spacing in the N-S direction is 7'-6". The pier spacing in the E-W direction is selected from load tables determined by the structural design for the specified slope, wind load, and snow load. The governing criteria for the pier spacing is either the spanning capacity of the cross pipes, the cantilever capacity of the pier. Simplified Load Tables 1A-I & 2A-I are included herein for reference.

Ground Screw Notes:

1. 2” Schedule 40 Pipe Compatible with:

	American Ground Screw Model 3 76mm x 3(+) mm	Krinner North America KSF G76
Screw Diameter:	2.99"	2.99"
Sleeve Diameter:	2.375"	2.375"
Minimum Screw Length:	51" or 63"	51" or 63"

2. 3” Schedule 40 Pipe Compatible with:

	American Ground Screw Model 3 102mm x 3.75(+) mm	Krinner North America KSF G114
Screw Diameter:	4.016"	4.488"
Sleeve Diameter:	3.5"	3.5"
Minimum Screw Length:	63"	63"

3. Tested Soil Class 4 Soil Properties: Friction Angle = 28-32 (deg), Total Unit Weight = 120-130pcf
4. Tested Soil Class 5 Soil Properties: Cohesion = 1000-2000psf, Total Unit Weight = 120-130pcf
5. Snow Load = 0 psf – tabulated values are conservative for Snow Loads > 0 psf
6. Soil classification is to be determined and verified by the end user of this certification letter.

The analysis assumes that the array, including the connections and associated hardware, are installed in a workmanlike manner in accordance with the IronRidge Ground Mount Installation Manual, the American Ground Screw Installation Manual, the Krinner Foundations Systems Installation Manual, and generally accepted standards of construction practice. Verification of PV Module capacity to support the loads associated with the given array shall be the responsibility of the Contractor or Owner and not IronRidge or Starling Madison Lofquist.

Please feel free to contact me at your convenience if you have any questions.

Respectfully yours,

Tres Warner, P.E.
Design Division Manager



8-1-22

Exp.
1/31/25